

SPECIFICATION FOR 3528 LED (YW-SPG3528A-19)

Features

- | Compatible with automatic placement equipment
- | Compatible with infrared and vapor phase reflow solder process
- | Mono – color – type
- | Pb - free

Applications

- | LCD back light
- | Mobile phones : LCD
- | Status indicators : Consumer & industrial electronics
- | General use

Absolute Maximum Ratings (Ta = 25°C)

Characteristic	Symbol	Value	Unit
Power Dissipation	Pd	70	mW
DC Forward Current	If	20	mA
Peak Forward Current *	I _{fp}	30	mA
Reverse Voltage	Vr	5	V
Operating Temperature	Topr	-30~+60	°C
Storage Temperature	Tstg	-40~+65	°C
Soldering Temperature (t≤5s,to shell 2mm)	Tsol	260°C MAX 5Sec	

*Pulse width 0.1msec max. Duty cycle 1/10

Electro- Optical Characteristics(Ta = 25°C)

Characteristic	Symbol	Min.	Typ.	Max.	Unit
Luminous intensity (IF=20mA)	IV	350	1000		mcd
Forward Voltage (IF=20mA)	VF	2.8		3.8	V
Viewing Angle (IF=20mA)	1/2θ		120		Deg
Reverse Current (VR=5V)	IR	0		10	uA

Note1: Tolerance of luminous intensity is ± 10%

Note2: Tolerance of forward voltage is ± 0.05V

Typical Electro-Optical Characteristics Curves

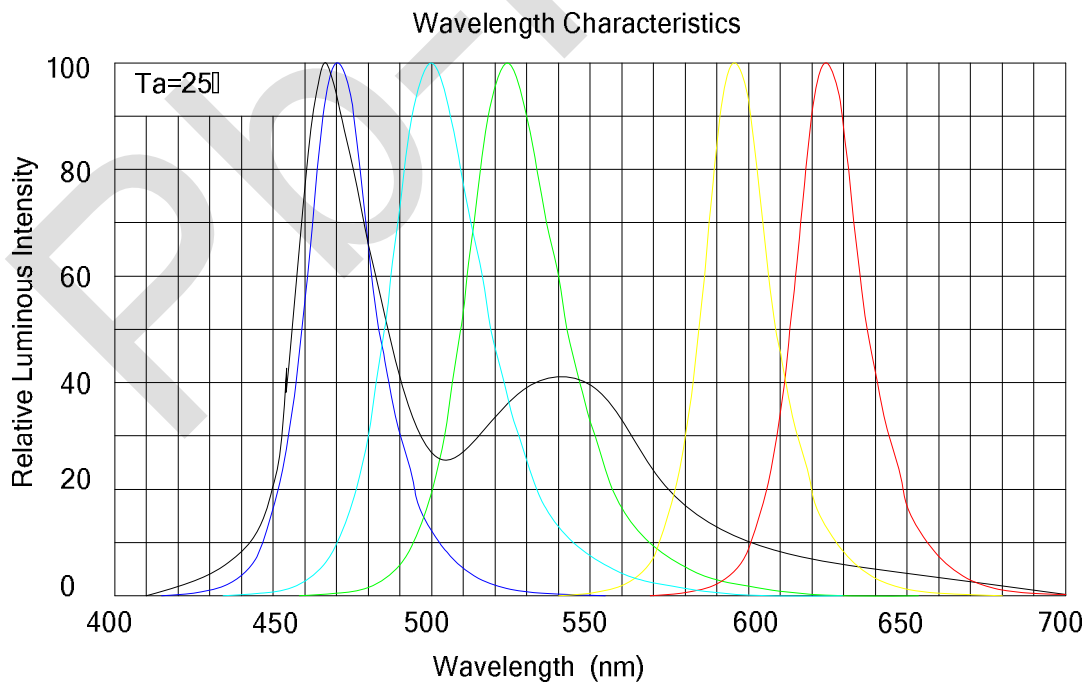

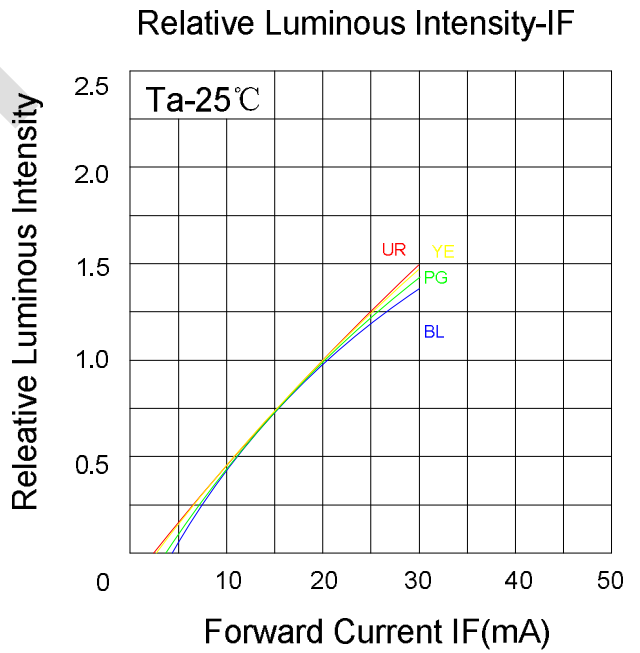
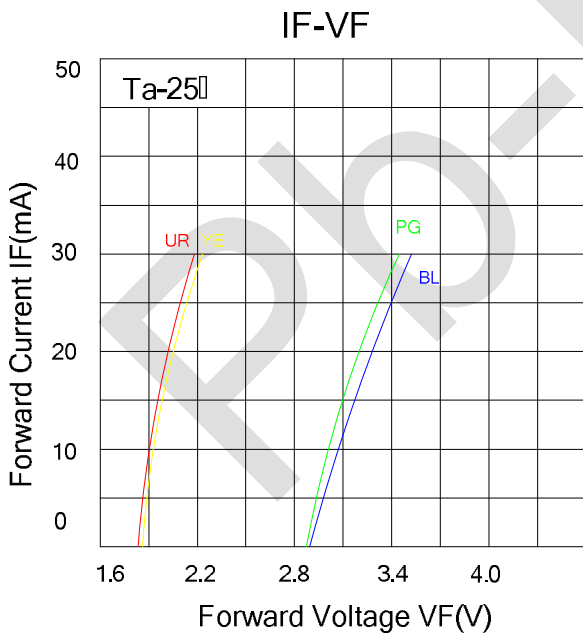
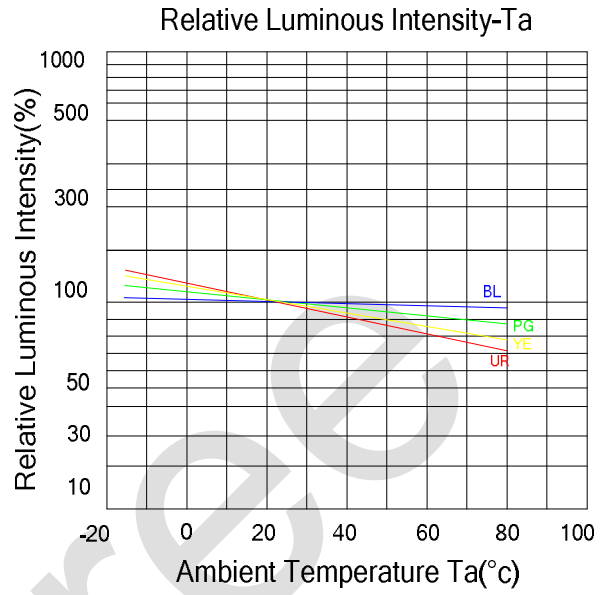
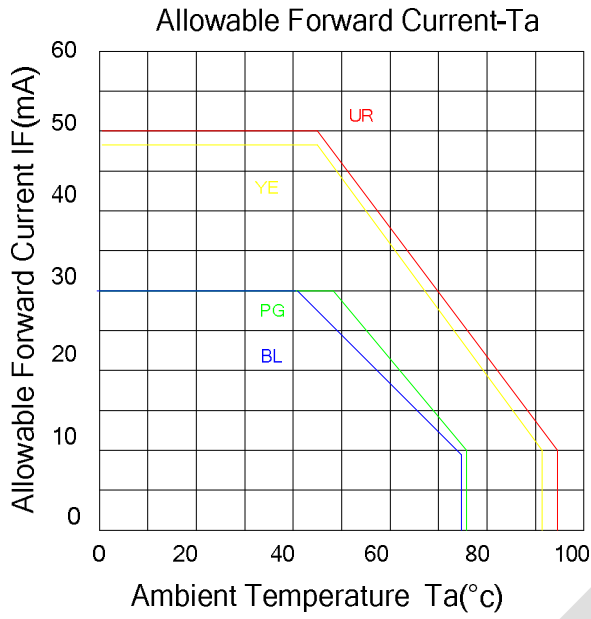

Package Outline:

Unit: mm

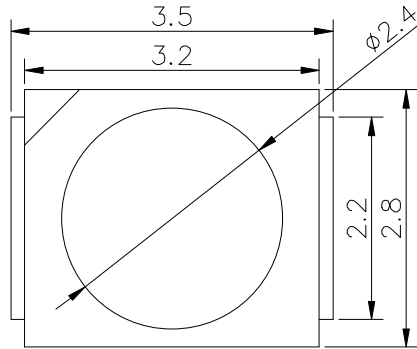

TOP VIEW

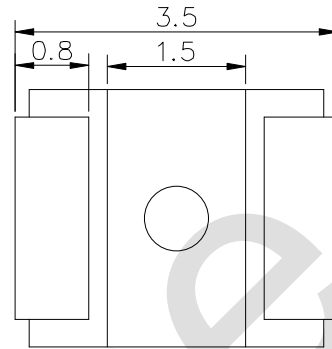

BACK VIEW

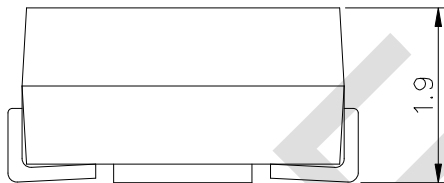

SIDE VIEW



POLARITY

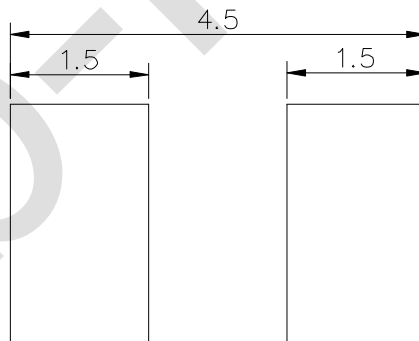

RECOMMENDED SOLDERING PAD DESIGN

NOTES

- 1: All dimensions are in millimeters
- 2: Tolerances are ± 0.1 mm unless otherwise noted

TAPE & REEL:

Unit: mm

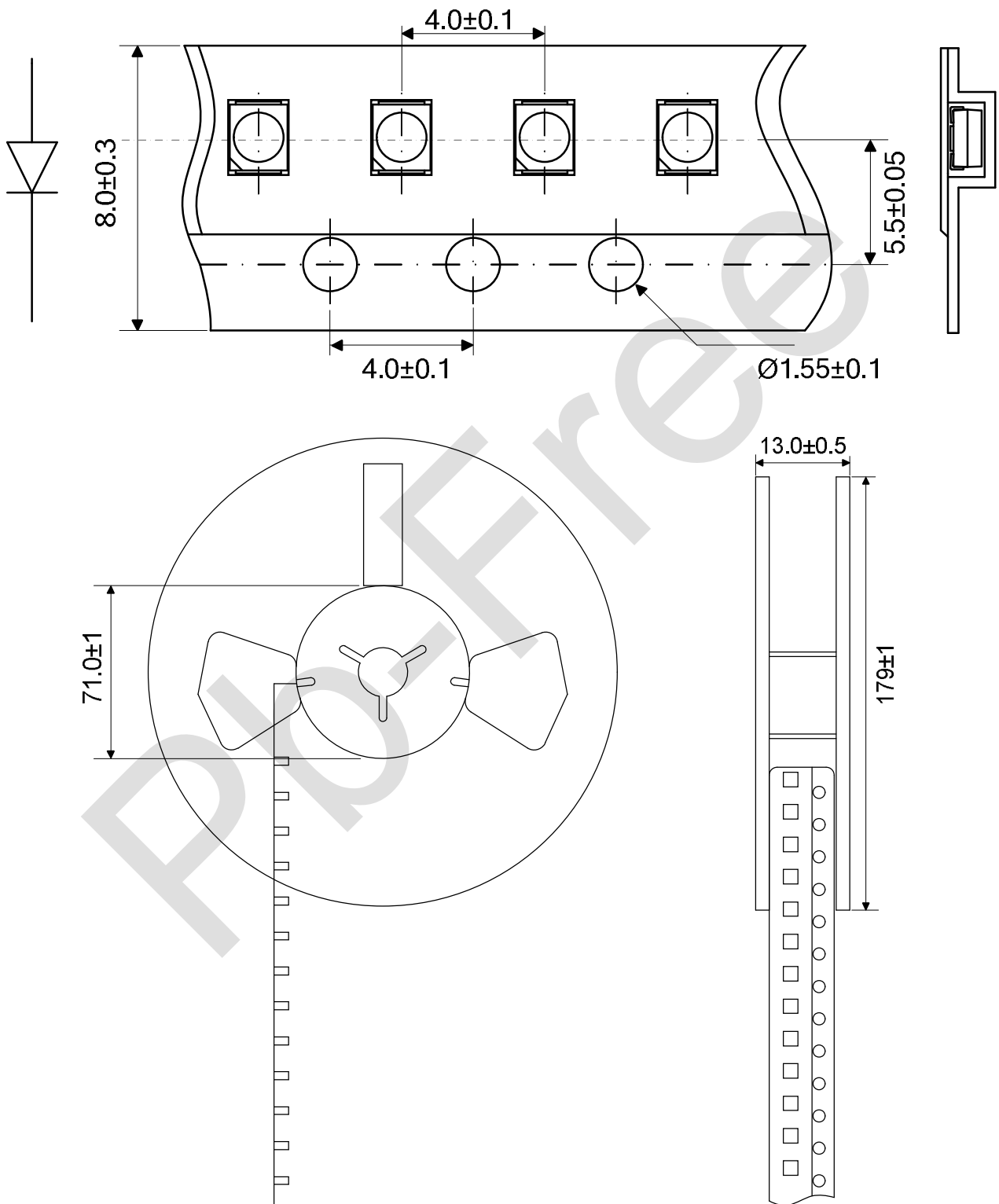

INFRARED REFLOW SOLDERING CONDITION (SUGGESTION)

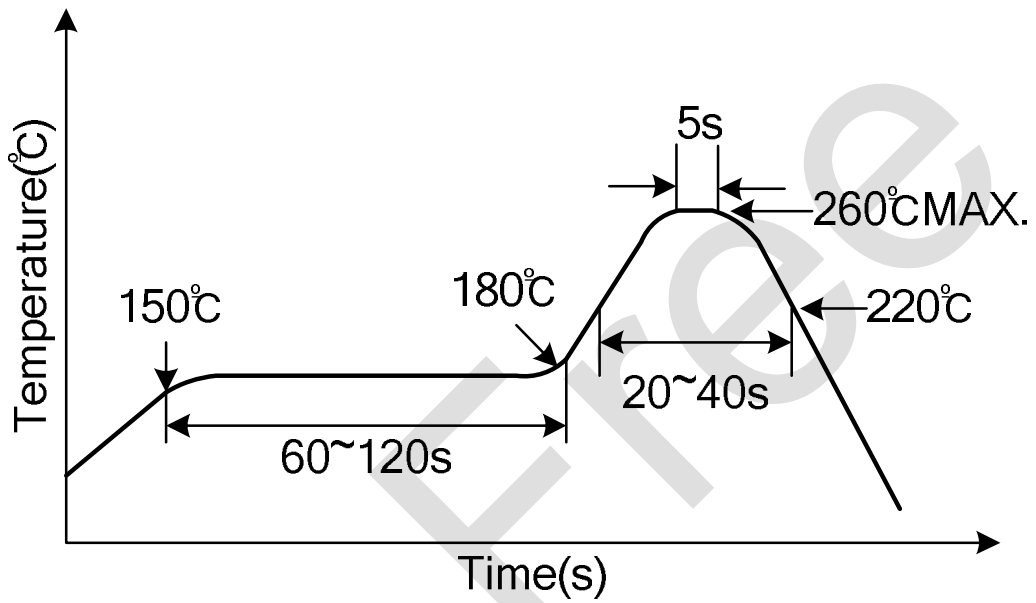

Reliability Test Items and Conditions

No.	Test Items	Test Conditions	Note	Result
1	Resistance to Soldering Heat	260°C±5°C	10Sec.	Pass
2	Thermal Shock	-20°C ~ 100°C 10Min. 5Sec. 10Min.	50Cycles	Pass
3	Temperature Cycle	-40°C 25°C 100°C 30Min. 5Min. 30Min.	100Cycles	Pass
4	Hi-Temp. Storage	100°C	1000Hrs	Pass
5	Low-Temp. Storage	-40°C	1000Hrs	Pass
6	Hi-Temperature/ Hi-Humidity Test	60°C/90%RH	1000Hrs	Pass
7	Operating Life	I _F =350mA	1000Hrs	Pass
8	Life Time 1	500mA@ROOM TEMP	1000Hrs	Pass
9	Life Time 2	350mA@--40°C	1000Hrs	Pass
10	ON/OFF Test	IF=700mA Pulse width 0.1msec max. Duty cycle1/10	100,000 Cycles	Pass